

CARGO TRUCKS

URAL NEXT



URAL NEXT 4320-6951-70



RELIABILITY

- Updated driveline with service life and reliability enhanced by 50%
- Pneumatic brake system with WABCO components
- High resistance to corrosion



CROSS-COUNTRY ABILITY

- Engine power up to 312 h.p.
- Differentials locking
- Central tire pressure control system



COMFORT

- New NEXT bonnet-type cab
- Air-sprung driver's seat
- Heat and noise insulation
- Optimal internal environment



GUARANTEE & SERVICE

- 24-month or 100,000 km guarantee
- 15,000 service-to-service interval



SAFETY

- Bonnet-type cab layout improving driver's safety
- RBL steering



COST EFFICIENCY

- Competitive price among similar vehicles
- Low cost of ownership

TECHNICAL DATA

URAL NEXT (URAL-4320-6951-70) MULTI-PURPOSE TRUCK

The URAL-NEXT (URAL-4320-6951-70) multi-purpose truck (6x6) is a further development of a line-up of the army vehicles belonging to Motor Locomotive family. The following modifications have been introduced in the design of the URAL Next trucks in comparison with the design of previous models of the URAL trucks:

- A new cab that has a traditional bonnet-type layout, but at the same time it combines up-to-date ergonomical characteristics with implementation of all modern solutions applied in vehicle cab equipment, including those by leading foreign companies;
- The cab ergonomics reduces driver's fatigue when marching, including on rough terrain for the account of using air-sprung seats, better ergonomics of the cab and applying new steering systems, a new gearbox and transfer box, heating and air-conditioning system, etc;
- A new cost-efficient Russian-made YAMZ-536 diesel engine, having a power ranging from 240 to 312 h.p., the YAMZ-0905/1105/1205 or ZF 9S1310TO mechanical gearboxes.

The URAL-NEXT (URAL-4320-6951-70) truck is intended for transportation of various cargoes, personnel, towing trailers and pull-type systems on all kinds of roads and terrain. The truck is distinguished by high mobility, floatation, reliability and easy steerability and operation.

Wheel arrangement	6x6
Kerb weight, kg	10 000
Gross vehicle weight, kg	22 500
Payload, kg	12 500
Trailer weight, kg	11 500
Cab seating capacity, including driver, people	3
Max. travelling speed, km/h	80
Engine	YAMZ-53642-10 turbo-charged diesel engine, / YAMZ-53602-10 with ignition, in-line, emission class 4 (UN ECE Regulation no. 96-02)
Rated power at 2100 min ⁻¹ , (h.p.) (kW)	209 (285) /312
Driveline	5- or 9-speed gearbox, YAMZ-1205 or YAMZ-1309 model, 2-stage transfer box
Cruising range at estimated fuel consumption, km	Not less than 1000
Ground clearance, mm	400
Obstacles surmounted:	
- Upgrade, %	Not less than 60
- Ford, m	1.75
Winch tractive force, t·f	7 - 9

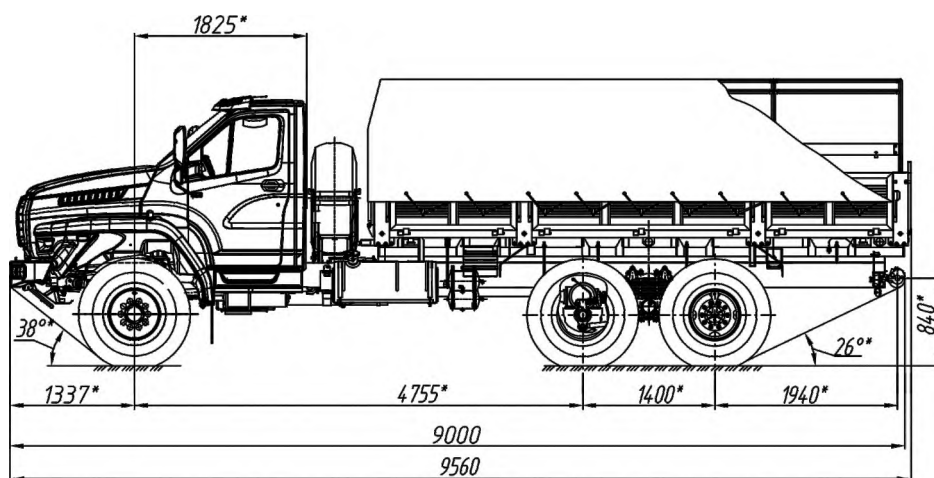

Exclusively Distributed by:



Cebu: 71 Juan Luna Ave. Kasambagan Mabolo, Cebu City • Telefax: 032.520.2214
Manila: Parc House 1, Suite 33, 227 EDSA Greenhills, Mandaluyong City 1554 • Telefax: 02.576.8606
Warehouse: Canaynay Avenue, BF Homes Martinville Subd., Manuyo Dos, Las Piñas, Manila
Davao: Diversion Highway, Matina Pangí, Talomo Davao City
www.conequip-ph.com • info@conequip-ph.com