

Big yellow

SELECTION BEYOND COMPROMISE

hyl5057jgk

Aerial Platform Truck

ISUZU NKR Chassis
High Working Height (14.2m)
Bucket Load (200kg)
Hook Lift Option (990kg)
Easy Maintenance



HYL SERIES

*Manufactured under stringent
German design and process*

BIG YELLOW SELECTION

*Highly Discipline selection process anchored on
reliability, functionality, efficiency, value for money,
quality, relevant innovation and aesthetic value*

hyl5057jgk / hyl5069jgka

Aerial Platform Truck

Chassis		Engine	
Model	ISUZU NKR77LLLWCJAY	Model	4KH1-TC EURO III
Cabin	Double, 4-doors, air Conditioner	Engine Power	96kw
Seat Capacity	5 Persons	Displacement	2.99L
Wheelbase	3360mm	Fuel Type	Diesel
Wheel Arrangement	4x2		
Steering	Power steering L.H.D.		
Gross Vehicle Weight	5700kg/6320kg		

Bucket		Boom	
Max. Working Height	14.2m/16.2m	Type	Three-section, Articulated
Max. Working Radius	7.1m/8.1m	Rotation angle	360°
Rated Load	200kg	Max. rising angle of upper and lower boom	70°/75°
		Max. rising angle of small boom	90°

Outrigger		Hook (Option)	
Type	H	Max. Lifting Height	8m/8.85m
Vertical Breadth	2700mm/L3013-R3172	Max. Lifting Weight	990kg
Horizontal Breadth	2650mm/F2650-R3280		
Adjustment	Adjusted separately		

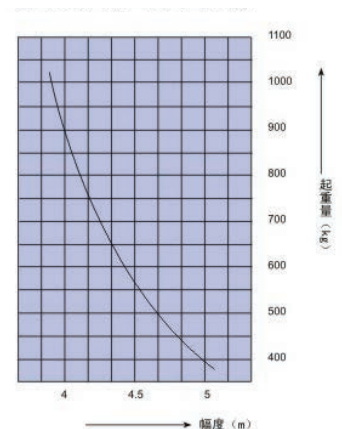
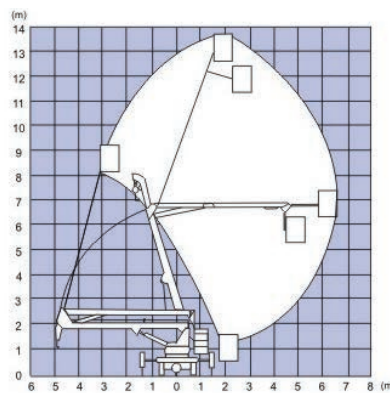
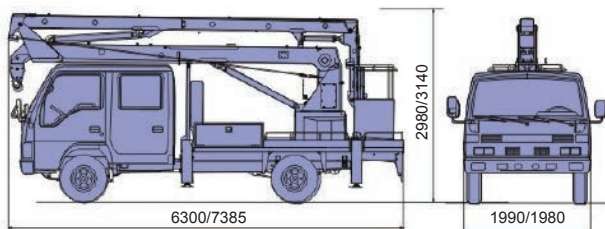

BIG YELLOW INTERNATIONAL LIMITED
www.bigyellow-sg.com

10 Anson Road, #21-07 International Plaza
Singapore 079903

Big Yellow and their respective logos, as well as corporate identity in this leaflet are trademarks of Big Yellow International Limited

* Specifications and design are subject to change without prior notice.

For more information on Big Yellow Products:

