

# CARGO TRUCKS

## URAL NEXT

URAL



### URAL NEXT AKN-10-OD PNR TRUCK



RELIABILITY

- Updated driveline with service life and reliability enhanced by 50%
- Pneumatic brake system with WABCO components
- High resistance to corrosion



CROSS-COUNTRY  
ABILITY

- Engine power up to 312 h.p.
- Differentials locking
- Central tire pressure control system



COMFORT

- New NEXT bonnet-type cab
- Air-sprung driver's seat
- Heat and noise insulation
- Optimal internal environment



GUARANTEE  
& SERVICE

- 24-month or 100,000 km guarantee
- 15,000 service-to-service interval



SAFETY

- Bonnet-type cab layout improving driver's safety
- RBL steering



COST EFFICIENCY

- Competitive price among similar vehicles
- Low cost of ownership

## TECHNICAL DATA

# URAL NEXT AKN-10-OD PNR TANK TRUCK

The AKN-10-OD PNR oil-field tank truck is designed for collection of spilt oil, gas condensate, petroleum products and non-aggressive process liquids as well as their transportation to the places of their salvage and re-processing.

Basic chassis	URAL - NEXT 4320-6912-74
Weight parameters	6x6
Kerb weight, kg	11 530
Gross vehicle weight, kg	21 300
G.V.W. distribution:	
Load on front axle, kg	5 300
Load on rear axle, kg	16 000
Cab	Type - bonnet-type, three-seat, two-door
Engine	YAMZ-53602.10 (Euro-4) Type - diesel / YAMZ-53642.10 with ignition, in-line, emission class 4 (UN ECE Regulation no. 96-02)
Rated power, h.p.	312 / 285
Gearbox	Model - ZF 9S1310TO, Type - Mechanical, 9-speed / YAMZ-1105, Mechanical, 5 speed
Tank capacity, m <sup>3</sup>	10
Number sections	1
Tank material	09G2S steel, S=5 mm
Internal anti-corrosion coating	TsVES zinc-filled coating
Cross section	Circle
Tank bottom version	Rear opening bottom
Arrangement of tank stiffening ribs	On tank outside
Tank-to-chassis frame fastening	With tie bands
Delivery-and-suction hose, m	6
Quick release coupling, mm	type - Camlock, Ø 102
Vacuum pump	Model - PNR-122, hydraulic drive
Pump delivery, m <sup>3</sup> /h	730
Inside diameter of vacuum manifold, mm	Ø 100
Fuel tanks capacity, l	300 + 210
Tires	Tire size - 425/85 R21
Overall dimensions of tank truck, mm:	
Length	9 310
Width	2 550
Height	3 810

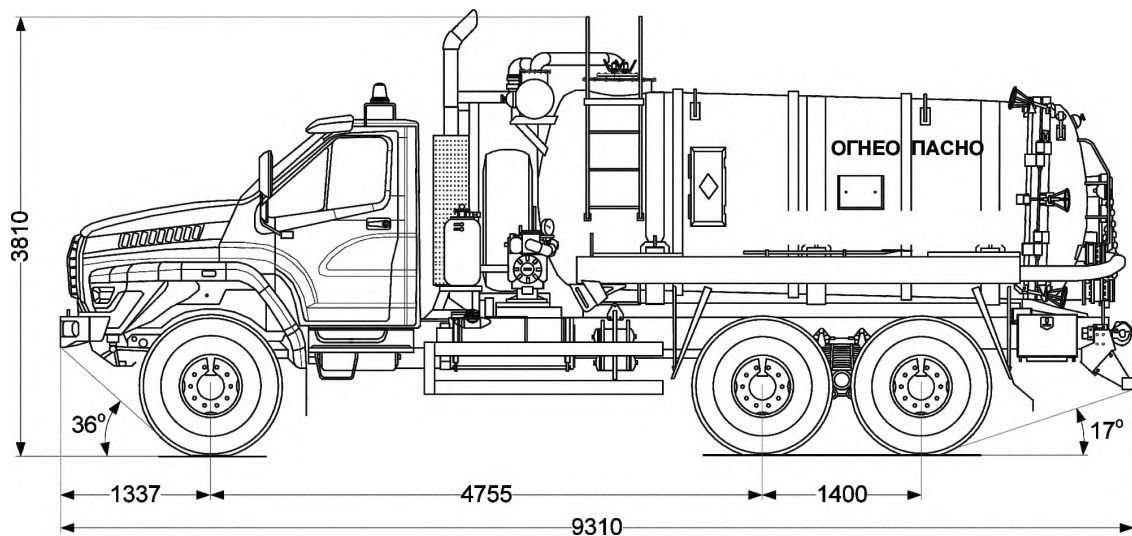

Exclusively Distributed by:



Cebu: 71 Juan Luna Ave. Kasambagan Mabolo, Cebu City • Telefax: 032.520.2214  
 Manila: Parc House 1, Suite 33, 227 EDSA Greenhills, Mandaluyong City 1554 • Telefax: 02.576.8606  
 Warehouse: Canaynay Avenue, BF Homes Martinville Subd., Manuyo Dos, Las Piñas, Manila  
 Davao: Diversion Highway, Matina Pangí, Talomo Davao City  
[www.conequip-ph.com](http://www.conequip-ph.com) • [info@conequip-ph.com](mailto:info@conequip-ph.com)